

16-output automatic band decoder for the antenna switches or filters

March 2018 OK2ZI

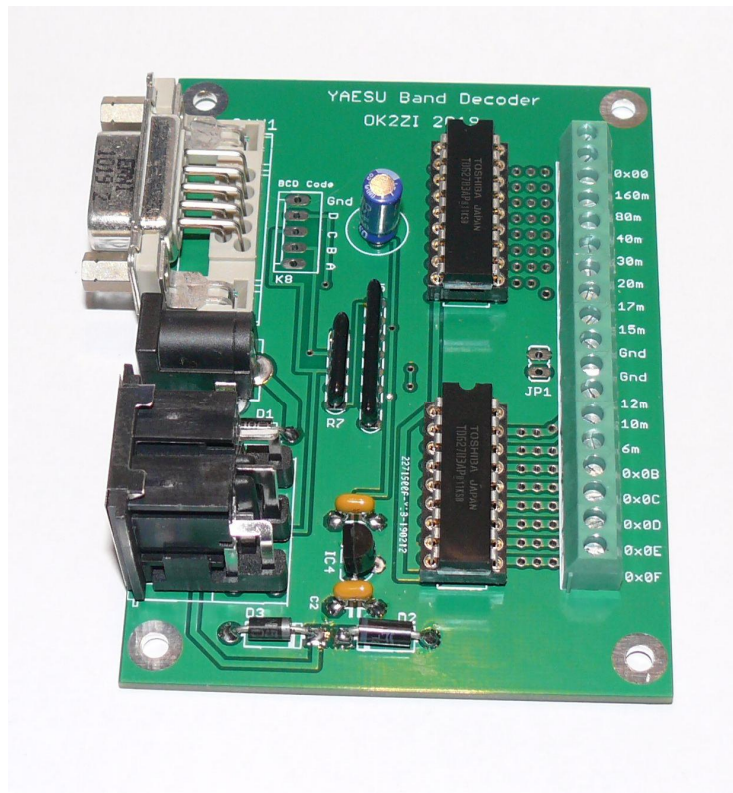
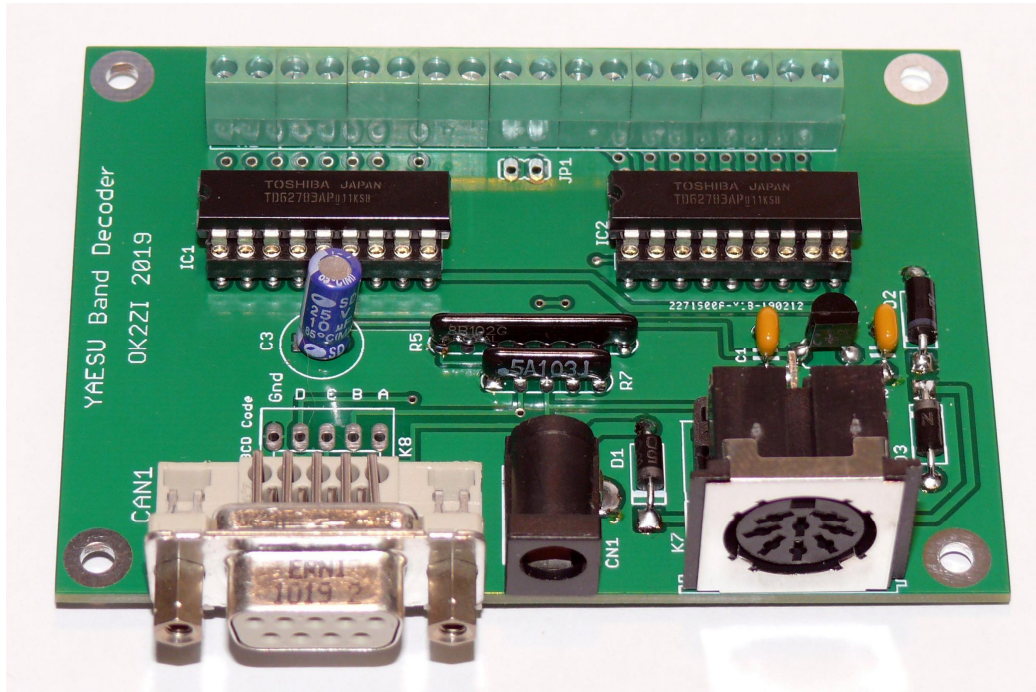

Rev 1.0

Introduction

The Automatic Band Decoder continuously decodes your transceiver's band changes and provides a separate output for each of the nine bands of your rig. By connecting an external antenna switch to the decoder's output, automatic and correct antenna selection is accomplished.

The Band Decoder is primary designed for Yaesu radios with band output signal BCD coded at TTL voltage levels.

However, it can be used with any other device that uses the same method of band coding at TTL voltage levels (for example Microham MK2R or LPT computer port). Then the computer running software may send the current band information to the computer's LPT port or to an auxiliary output at Microham MK2R. Many computer logging programs support this feature now, which can be useful if you have a Kenwood or an Icom transceiver. Consult your transceiver and software manuals on how to interface your radio to the computer and how to enable the software's antenna control feature.

If you want to use an another kind of controller (like Arduino, RaspberryPI etc.), then the different bands are coded as follows:

Binary code	Band / Output
0000	0x00
0001	160m
0010	80m
0011	40m
0100	30m
0101	20m
0110	17m
0111	15m
1000	12m
1001	10m
1010	6m
1011	0x0B / 2m
1100	0x0C / 70cm
1101	0x0D
1110	0x0E
1111	0x0F

Table 1.

The Band Decoder provides source driver outputs, which provide a source of 12Vdc for the "hot" side of external relays (common point for the relays is a ground or minus pole).

All of the antenna switches designed by OK2ZI are controlled by this way, but you can control many other products with the same method of switching.

Circuit Description

The schematic of the Band Decoder is shown in Figure 1.

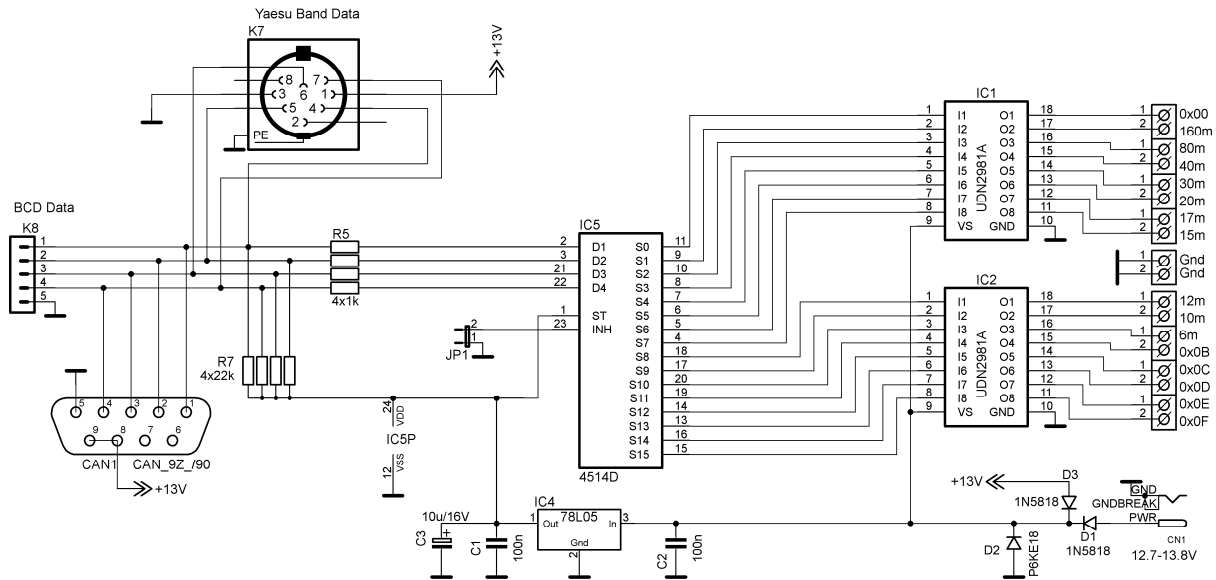

Figure 1.

The decoder accepts a four bit binary-coded decimal (BCD) word at TTL levels and decodes it at IC5 (a CMOS BCD-Decimal Decoder). Data Bit A is the Least Significant Bit (LSB) and Data Bit D is the Most Significant Bit (MSB). All nine bands are decoded as described in Table 1. The outputs of IC5 go high to reflect that band in use.

Jumper JP1 – if open inhibits the decoder and all outputs are deactivated.

Eight of the IC5 outputs are routed to IC1, and next eight of the IC5 outputs are routed to IC2. IC1 and IC2 contain eight N-channel Darlington pair transistor switches, see Figure 2.

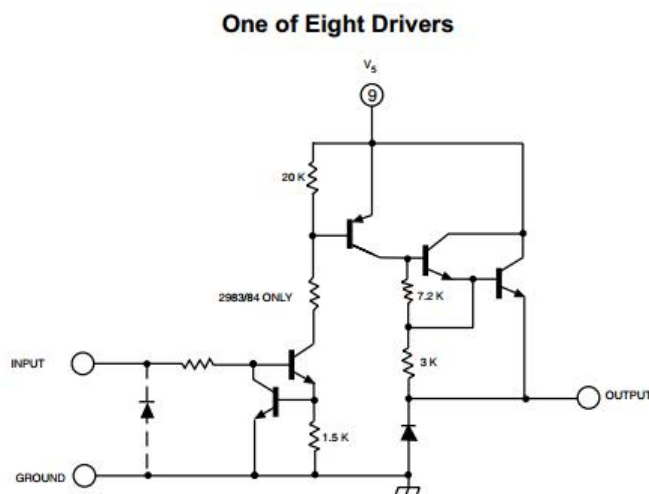

Figure 2.

All 16 switches function in the same manner. When their input goes high, their output switches high. All unselected outputs float at ground level if connected to the antenna switch relays.

Please note: Output current capability is min. 350mA per output, but the total dissipation of whole IC must be kept under 2W. The average output Darlington pair saturation voltage is 1.7V, therefore the power supply must deliver at least 13.7V for the 12V relays ! More information can be found in the datasheets for UDN2981 or TD62783.

The Band Decoder is powered-through either the CN1 power jack or via the "data" cable from the transceiver or via the D-SUB9 connector. Diodes D1 and D3 isolate these two sources to prevent circulating currents in case voltage is applied to both inputs simultaneously. **DO NOT!!** Power the module via the CAN1 and K7 simultaneously. If the voltage drop 0.5V [at the diode is significant for the function, you must use higher power supply voltage. 14-15V should be enough for 12V relays. If you can't use higher supply voltage than 13,8V then remove the appropriate diode and substitute a wire bridge in its place. D2 is a protection transient voltage suppression diode P6KE18A with the 18V clamping level for the protection of the relays from overvoltage. If you want to optionally use 24V relays then replace D2 with P6KE27A or with P6KE30A for 26V relays.

BCD decoder CMOS4514 is powered from 5V monolithic stabilizer IC4 – 78L05. Resistor networks R5 and R7 are for EMI protection.

The Band Decoder can be connected to the transceiver via DIN8 connector K7 or via header connector K8 or via D-SUB9 connector. The pinout of K7 is the same as on the YAESU transceivers.

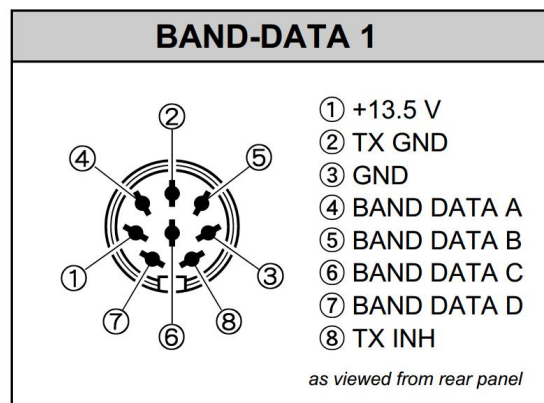

Band data pinout at Yaesu DIN8 band data connector.

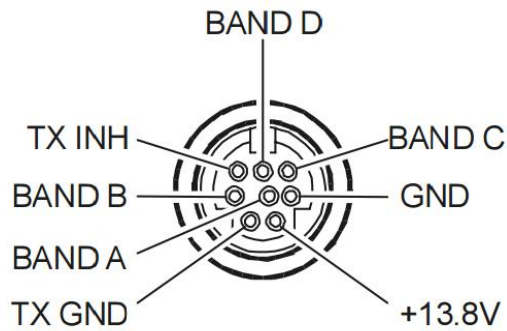

Band data pinout at Yaesu Mini-DIN8 band data connector.

Pin	Signal
1	BAND A
2	BAND B
3	BAND C
4	BAND D
5	GND
6	Not connected
7	Not connected
8	+13.8V
9	+13.8V

Band data pinout at D-SUB9 connector.

I don't offer the cable between transceiver and the Band Decoder. For the transceivers with the Mini-DIN8 you can buy standard Yaesu CT-58 cable, for the transceivers with the DIN8 search the Web and eBay. Those cables are available from other sellers.

The antenna switch relays are connected via the terminal blocks. Do not forget to connect also the power ground from the terminals marked as GND.

Applications

With the Band Decoder you can control up to 16 separate relays one for each band (or BCD combination).

Very often many Hams use multiband antennas and then less amount of relays are needed. In this case you can combine the Band Decoder outputs in parallel.

Examples:

1. You have 4:1 antenna switch and 4 antennas, but only 2 are mono-band antennas.

Band	Antenna	4:1 Switch Port	Band Decoder outputs combination
160m	Dipole	1	160m
80m	Inverted Vee	2	80m
40m	40/30 GP	3	40m+30m
30m	40/30 GP	3	40m+30m
20m	5 band Yagi	4	20m+17m+15m+12m+10m
17m	5 band Yagi	4	20m+17m+15m+12m+10m
15m	5 band Yagi	4	20m+17m+15m+12m+10m
12m	5 band Yagi	4	20m+17m+15m+12m+10m
10m	5 band Yagi	4	20m+17m+15m+12m+10m

The Band Decoder outputs can be combined at the PCB with short wires or at the terminal block. See images.

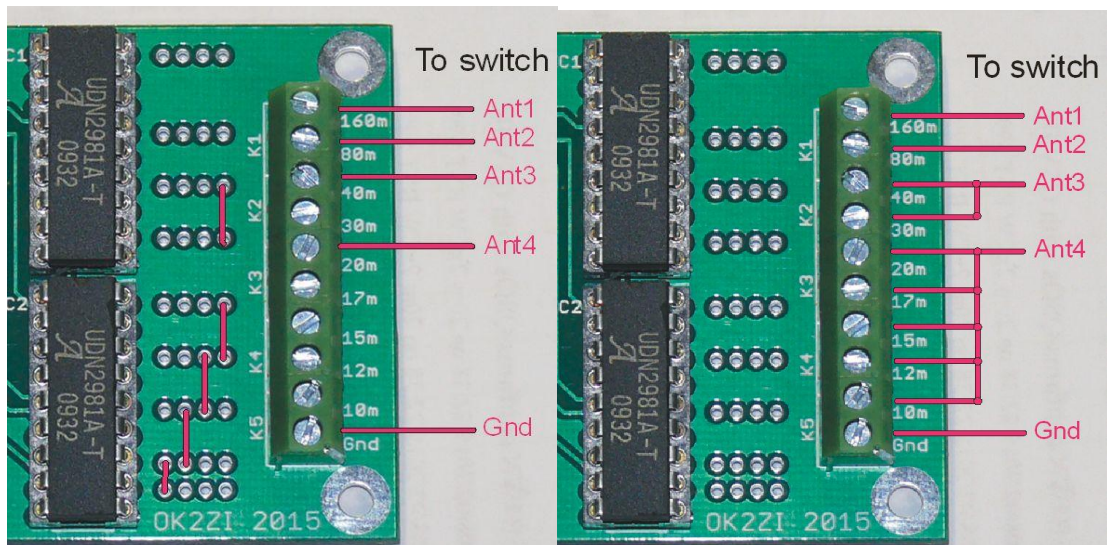

On board connection

Out of board connection

Note: Pictures are taken from 9-output band decoder, but the principle is same.

2. You have 6:1 antenna switch and 6 antennas, and 2 are multi-band antennas.

Band	Antenna	6:1 Switch Port	Band Decoder outputs combination
160m	160m Dipole	1	160m
80m	80m Inverted Vee	2	80m
40m	40m Ground Plane	3	40m
30m	30m Dipole	4	30m
20m	20m-15m-10m Yagi	5	20m+15m+10m
17m	17m-12m Yagi	6	17m+12m
15m	20m-15m-10m Yagi	5	20m+15m+10m
12m	17m-12m Yagi	6	17m+12m
10m	20m-15m-10m Yagi	5	20m+15m+10m

Summary specification

Power Supply Voltage	+12 to +15 volts dc
Quiescent Current required (no relays activated)	10 mA
Output current capability	350 mA per output
Total output current capability (for whole Band Decoder)	1000mA (limited by D1 or D3)
Dimension	65x90mm

Any suggestion, comments or questions are welcomed at email [ok2zi \(at\) atlas.cz](mailto:ok2zi(at)atlas.cz).